

Weights in Kg

Top.....	2.14
Shelf.....	1.75
Bottom.....	1.40
Body Panel.....	5.63
Pole Set (four pieces) D.....	2.12
Header.....	0.96
Round Tray.....	0.95
Bag.....	1.70

Packaging in Kg

Individual reusable carton	2.2
External size: 1295(w) x 675(d) x 135mm(h)	
Second Shelf carton	0.85
External size: 1255(w) x 530(d) x 45mm(h)	
Round Tray carton	0.45
External size: 523 (w) x 523 (d) x 83mm(h)	

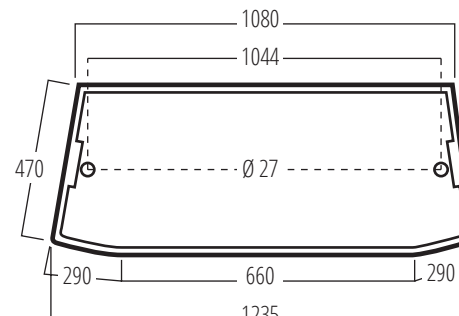

Top

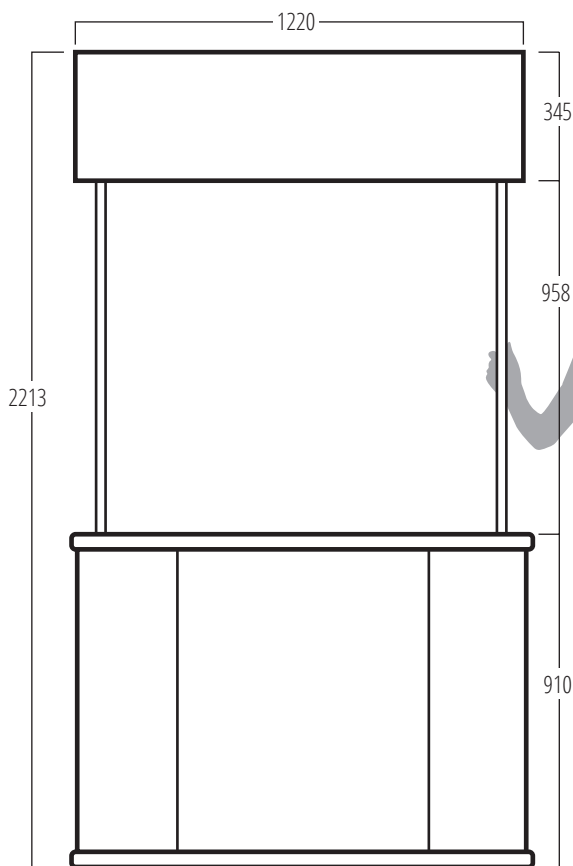

Unit and Header

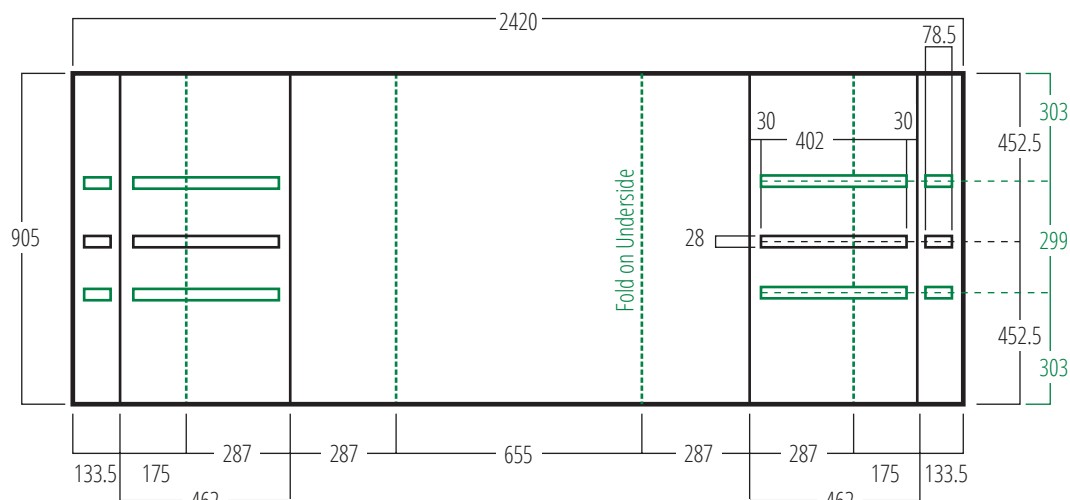

Graphic Size for One and Two Shelf Unit

Allow 37.5mm for top and bottom

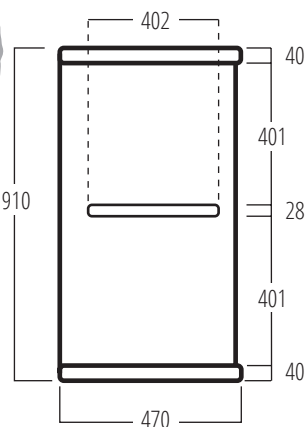

Side - One Shelf

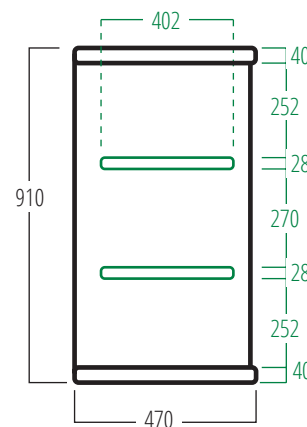

Side - Two Shelves

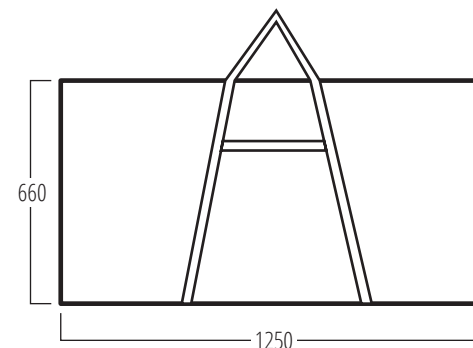

Carry Bag

